

© DEN HARTOG INDUSTRIES, INC.

Copyright. All information furnished within this document, electronic file or design correspondence is the property of Den Hartog Industries, Inc. and shall not be used, disclosed to others or copied without the expressed written consent of Den Hartog Industries, Inc.

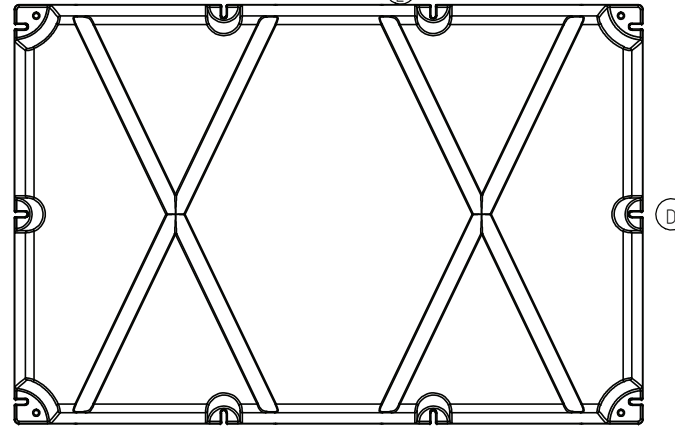
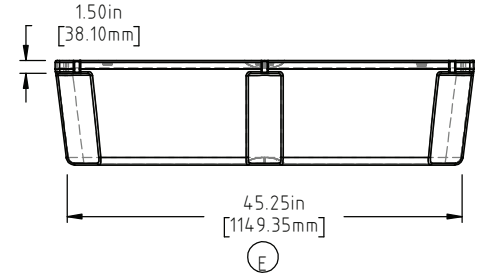
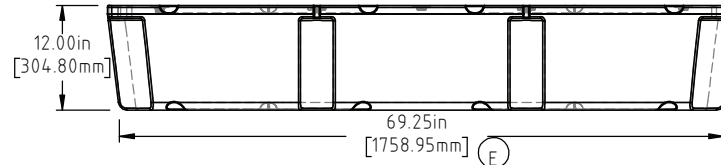
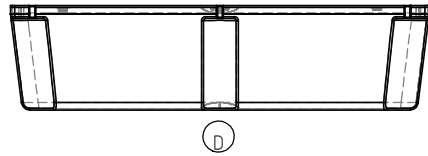
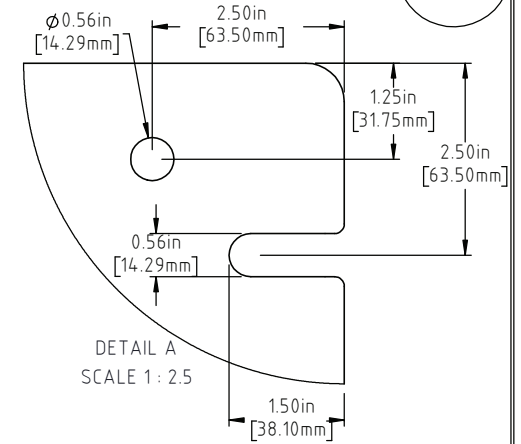
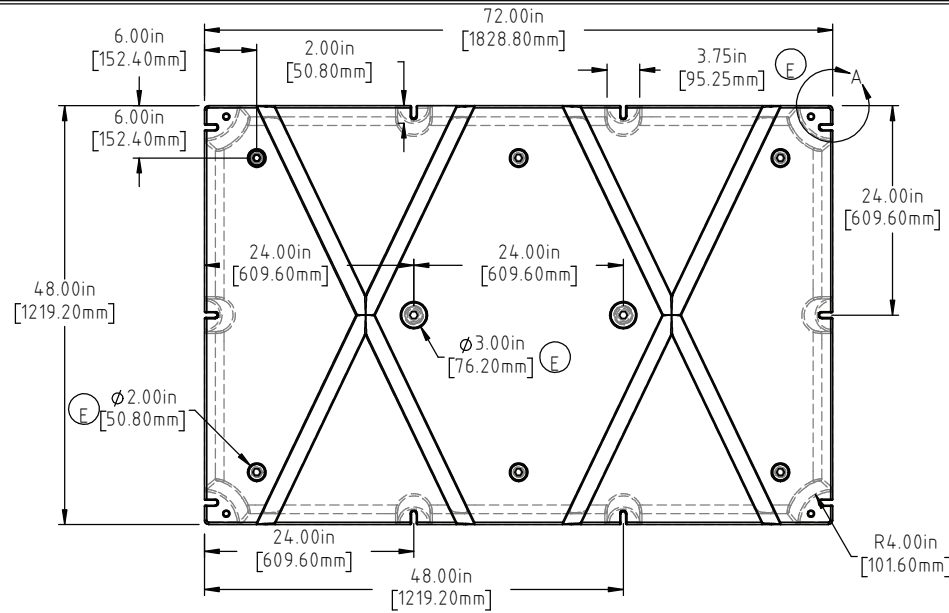

NOTE: BUOYANCY IS 1369 LBS.(620.97 KG)

E	DIMENSIONS UPDATED. SPINWELD DETAILS ADDED.	ADH 11/16/16	3321
D	BOTTOM/SIDE VIEWS ADDED TO PRINT.	ADH 12/4/14	2971
C	78 LBS WAS 77 LBS, 1369 LBS WAS 1350 LBS	ADH 6/25/12	2420
B	METRIC DIMENSIONS ADDED	ADH 6/18/08	1685
A	ADD BUOYANCY NOTE	GWC 1/10/07	
A	CHANGE WEIGHTS FF WAS 97	GWC 1/10/07	
REV	DESCRIPTION	BY / DATE	CCN

DRAWN / DATE DEAN 11/18/94	MATERIAL POLYETHYLENE E
APPRD. / DATE ADH 11/6/07	

ALL DIMENSIONS ARE IN DECIMAL INCHES TOLERANCES UNLESS OTHERWISE SPECIFIED
 POLYETHYLENE
 ±1% @ 68°F

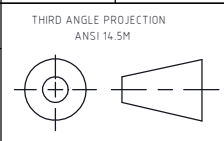

SHOT WEIGHT: 54 LBS. (24.49 KG.)
 SHIPPING WEIGHT: SEE NOTES
 FINISH:

NOTES: (A)(C)
 1.) AF 54 LBS. (24.49 KG.)
 2.) FF 78 LBS. (35.38 KG.)
 3.) 0.150 IN (3.81 mm) NOM. WALL



Den Hartog INDUSTRIES, INC.

Ace Roto-Mold Injection Molding Blow Molding Sowjoy

4010 HOSPERS DRIVE S. BOX 425, HOSPERS, IOWA 51238-0425

DESCRIPTION	48 X 72 X 12 FLOAT	
SCALE	N.S.	PART NO. 4872-12