

© DEN HARTOG INDUSTRIES, INC.

Copyright. All information furnished within this document, electronic file or design correspondence is the property of Den Hartog industries, Inc. and shall not be used, disclosed to others or copied without the expressed written consent of Den Hartog Industries, Inc.

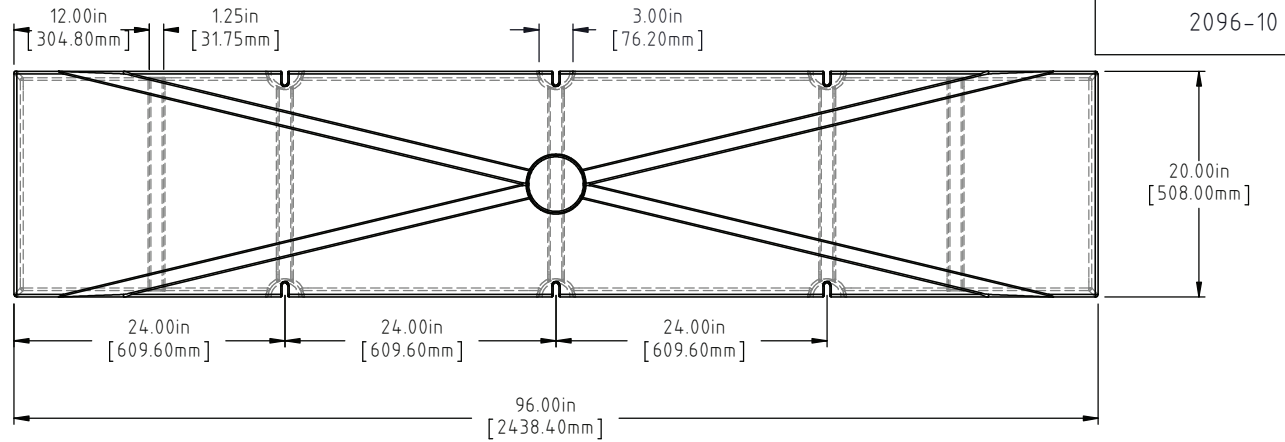

G

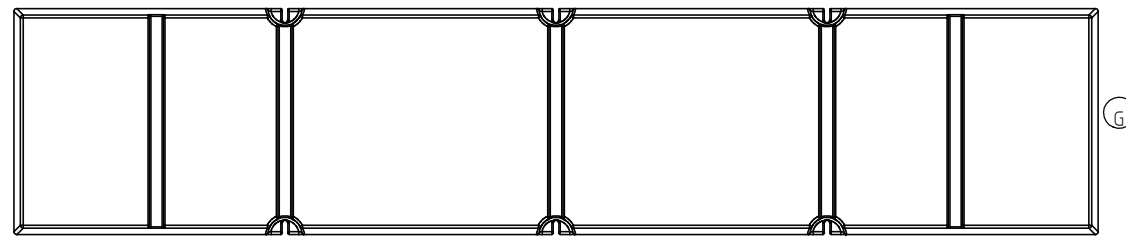
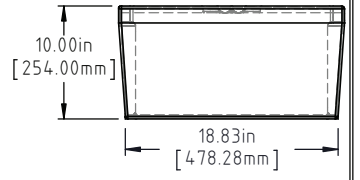
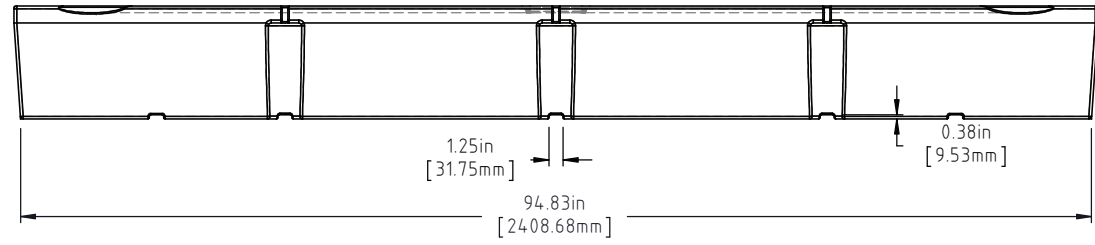
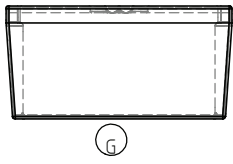

G	BOTTOM AND SIDE VIEWS ADDED TO PRINT	ADH 12/4/14	2971
F	592 LBS WAS 591 LBS, 50 LBS WAS 49 LBS.	ADH 6/5/12	2420
E	591.00 LBS WAS SHOWN AS 343.00 LBS DRAWING TEMPLATE UPDATED	ADH 10/17/11	2309
D	METRIC DIMENSIONS ADDED	ADH 6/11/08	1685
C	CHANGE DRAWING NUMBER	GWC 11/29/06	
B	CHANGE WEIGHT	GWC 11/29/06	
A	ADD BUOYANCY	GWC 11/29/06	
REV	DESCRIPTION	BY / DATE	CCN

DRAWN / DATE DHJ 7/29/03	MATERIAL POLYETHYLENE
APPRD. / DATE ADH 11/5/07	

(A)(E)(F)
NOTE, BUOYANCY 592.00 LBS. (268.53 KG.)



Den Hartog
INDUSTRIES, INC.

Ace Roto-Mold Injection Molding Blow Molding Sowjoy

4010 HOSPERS DRIVE S. BOX 425, HOSPERS, IOWA 51238-0425

ALL DIMENSIONS ARE IN DECIMAL INCHES
TOLERANCES UNLESS OTHERWISE SPECIFIED
POLYETHYLENE
±1% @ 68°F

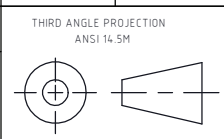

SHOT WEIGHT:
39 LBS. (17.69 KG.)
SHIPPING WEIGHT:
SEE NOTES.
FINISH:

NOTES: (A) (F)
1.) AF 39 LBS. (17.69 KG.)
2.) FF 50 LBS. (22.68 KG.)

DESCRIPTION	20 X 96 X 10 FLOAT	
SCALE	N.S.	PART NO. 2096-10